

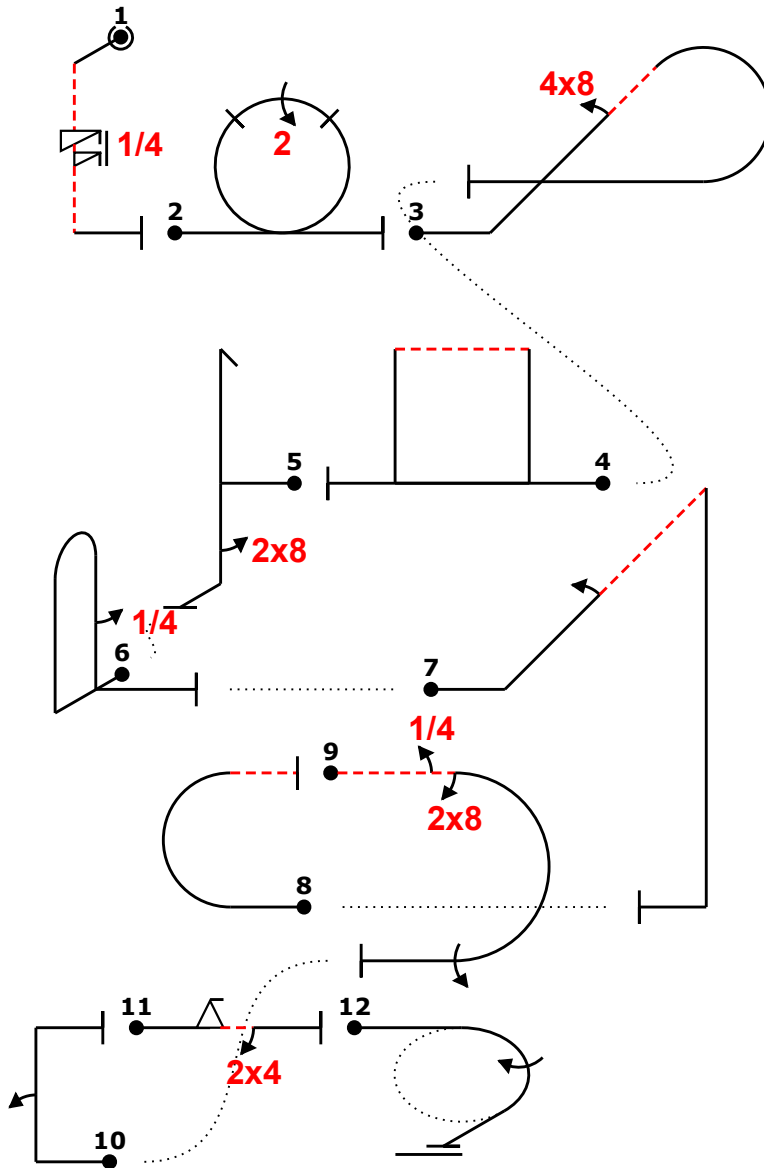

Pilot ID		Form B
CIVA Intermediate Unknown1		Flight #

wind/vent ←



Power			
Fig	Aresti	K	
1	1.1.6.3	10	14
F	9.11.1.5	4	
2	7.4.1.1	10	19
B	9.2.3.4	9	
3	8.5.2.1	10	19
D	9.8.2.2	9	
4	7.4.3.1	14	14
E			
5	5.2.1.1	17	20
I	9.8.5.1	3	
6	8.4.1.1	13	15
C	9.1.5.1	2	
7	1.2.3.1	12	18
H	9.1.2.2	6	
8	7.2.1.1	6	12
Add.			
9	7.2.1.4	6	19
A	9.1.3.1	2	
	9.8.3.1	3	
	9.1.3.4	8	
10	1.1.6.1	10	12
Add.	9.1.1.2	8	
11	1.1.1.1	2	18
J	9.9.3.2	11	
	9.4.3.2	5	
12	2.1.3.1	14	14
G			
Total K = 194			

Check: 8-9-2020 21:45 OpenAero 2020.1.9 2020 civa intermediate unknown1 Sequence is correct
 ej "8F" iv5a "8B" o22 "8D" 48rc (12,18) "8E" go "8I" h8 (0,2) "8C" b"4 (10,0) "8H" .12."t....." (-16,0) "8L" m- "8A" 4s -4,8al
 (-11,12) "8L" v2 "8J" 2f,24 "8G" 1j1

Proposal D pilot
 A/C